

Mary Visits Elizabeth

Jesus
Lesson 2

Lesson Objectives

- The children will identify Mary and Elizabeth as relatives and good friends who served God.
- The children will each select a person to be a friend to.
- The children will identify different ways they can share God's "good news."

Lesson Text

Luke 1:39-56

Scripture Memory Verse

"This is my Son, whom I love; with him I am well pleased."

Matthew 3:17

Lesson Plan

Greeting and Registration

Preclass Activity: Friendship Collage

Welcome and Singing

Centers:

Bible Story: The Visit

Life Application: Friendship Web

Craft: Good News Pouch

NOTE: Be sure to allow sufficient time for a snack.



Mary Visits Elizabeth

Friendship Collage

The children will make a collage of pictures of people, representing friends.

Materials

For each child:

- glue stick

For the teacher:

- magazines
- one large poster board, 12" x 18" (or other stiff paper)
- scissors

Preparation

Cut out enough pictures of people from the magazines to cover the poster board.

Instructions

1. Have the children select pictures and glue them onto the poster board.
2. Encourage the children to work together to cover the poster board with the pictures.
3. As they are doing this, ask them questions about friendship, such as:
 - Do you think the mailman can be your friend?
 - Could you and your grandmother be good friends?
 - Could your own brother or sister be your friend?

Teacher Tips

- Let the children have fun. There's no right or wrong way to do this activity.
- If possible, use photographs of people that the children know, such as their friends in class or at church.

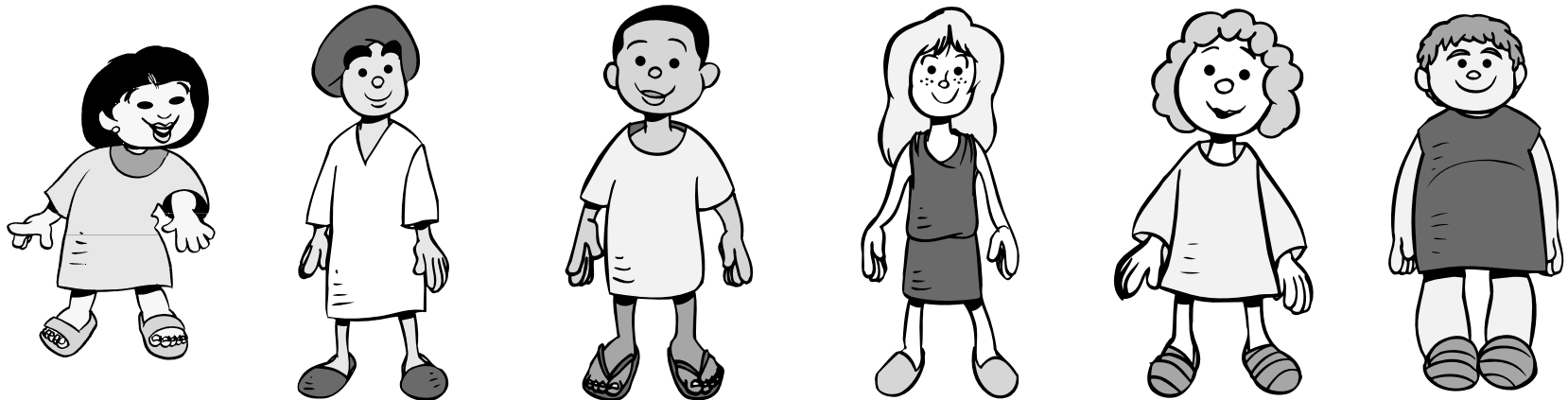

Mary Visits Elizabeth

The Visit

The children will hear the story of Mary's visit to her relative, Elizabeth.

Lesson Text

Luke 1:39-56

Materials

For the teacher:

- magazines
- construction paper
- glue
- scissors

Reproducible Pages:

- Page A, 1 copy for the teacher

Preparation

Ask a woman in your congregation to play the part of Mary for your class. Give this woman the copy of Reproducible Page A. She will need to read through the story and be prepared to tell it to the class. She will also need to be prepared to answer questions relating to the story. She will also need to wear a sheet with a pillow underneath, so that she looks pregnant, and a scarf covering her hair.

Mary's Visit

It all happened a very long time ago, but I remember how happy I was when God told me I was going to be the mother of Jesus. I just had to take a trip to see Elizabeth, my relative and friend, and tell her my exciting news! Elizabeth was also going to have a baby. We were both going to have babies! Her baby was going to be called John. John would become Jesus' relative and friend.

I could hardly wait to see Elizabeth. As I walked into her house, she was very happy to see me! She said that when she heard my voice, her baby jumped inside her! (Luke 1:42-45).

There was so much to talk about, and so much to do to get ready for our babies, that I stayed at Elizabeth's house until it was time for her baby to be born. I enjoyed being able to help Elizabeth with her work. I was so glad I could help my friend.

We had to carry water from the well every day. We cleaned the house, washed the clothes and cooked the meals. We also prayed together every day and worshipped God. Many times we visited with Elizabeth's neighbors, talking with them about our happy news and about God.

We loved our long visit together. We loved being friends.

Conclusion

Let the children ask Mary any questions that they may have.

Teacher Tips

- Encourage the children to share about ways they can relate to the story i.e.: "I have a relative."
- Be sure that the woman portraying Mary is prepared to answer questions. Also be sure that she understands to answer only from what the Bible says about Mary.

Mary Visits Elizabeth



Mary Visits Elizabeth

Friendship Web

The children will help construct a Word Web about friendship.

Scripture Memory Verse

"This is my Son, whom I love; with him I am well pleased."
Matthew 3:17

Materials

For the teacher:

- magazines
- 1 piece of poster board or a large white piece of paper
- 3" x 5" cards or pieces of paper
- scissors

Preparation

Cut out pictures from the magazines that illustrate things that friends do together.

Instructions

Ask the children what they talked about in the Preclass Activity.
That's right. You talked about friends.

Write the word "friend" in the middle of the poster board. *We are going to make a Word Web. In the middle of the web, I wrote the word, friend.*

Here are pictures of friends doing different things together. Hold up one of the pictures, for example, a picture of people playing ball. What are these friends doing in this picture? That's right, they're playing ball. Write the words "play ball" on the poster board, tape the picture above the words, and draw a line from the picture to the word, friend. See Figure A.

Continue in this manner with each of the pictures that you cut out of the magazines. Ask the children: *Are there other things that you like to do with your friends?* As the children answer, write words for their ideas on the poster board and draw lines from their words to the word, friend. You may also choose to draw pictures of their ideas.

After you have used all of the pictures and collected enough ideas, continue a discussion with the children about where we can find our friends, asking them questions, such as:

- Should we be friends with people we meet at school?
- Should we be friendly when we meet new people with our mom?
- Can we make new friends at the park or the library?

Scripture Memory Activity

Ask the children: *Who remembers the memory scripture?* Choose a child to whisper the scripture in your ear. If correct, have them encourage their friends to remember by giving them hints.

Hints should be short and easy, such as the first few words of the scripture.

Conclusion

Let's thank God for giving us friends. Choose a child to pray and thank God for our friends.

Jesus taught us how to be friends. He talked with his friends about God. Who do you want to tell about God this week? Have each child name a friend they will tell about God this week. Write the name of each child's friend on a 3" x 5" card and give it to them to take home. This card will help to remind you to talk to your friend about God.

Teacher Tips

On the back of the poster board create another word web with the word "friend" asking the children: Who are our friends?



Mary Visits Elizabeth

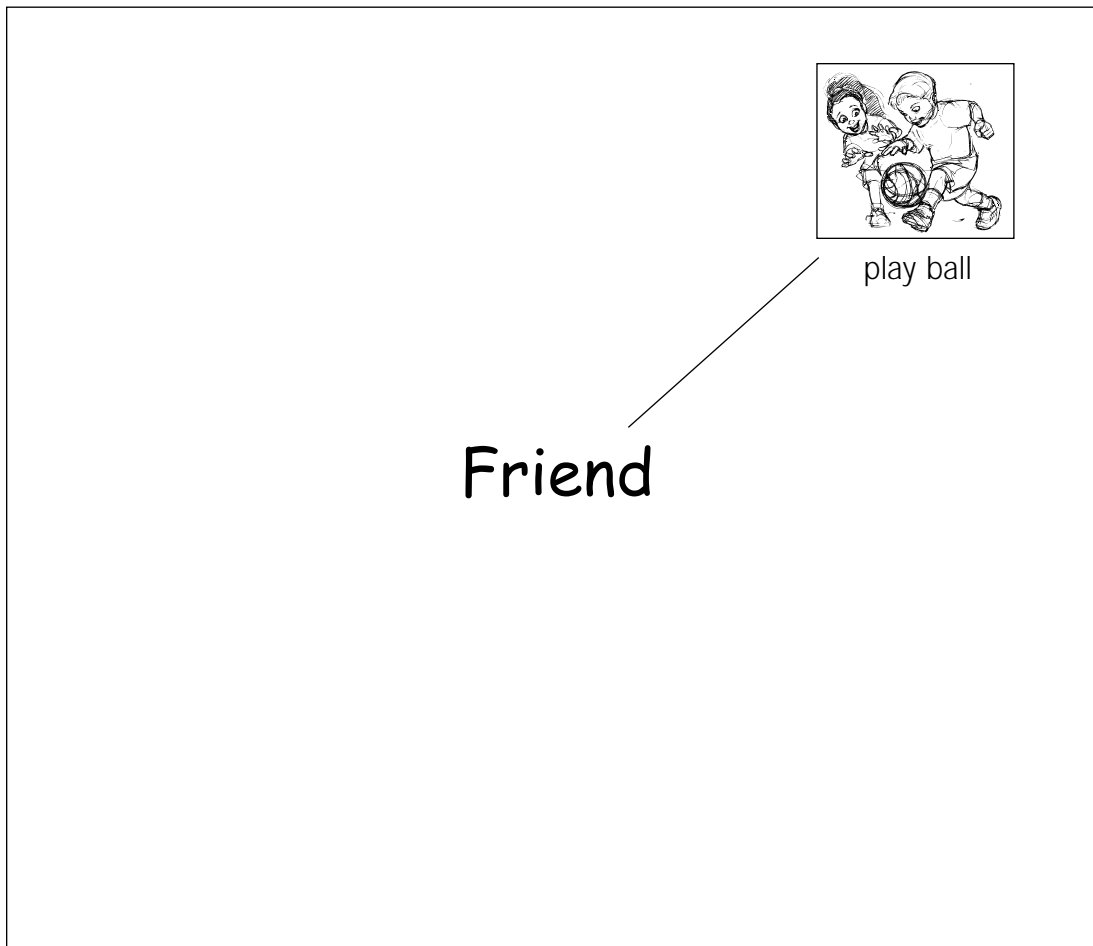

Mary Visits Elizabeth

Good News Pouch

This craft will help the children to share with their friends the good news that Jesus was born.

Materials

For each child:

- 1 paper plate, 9"
- 2 pieces of yarn, 24" long
- markers
- glue stick
- scissors
- 2 church invitations

For teacher:

- 1 paper plate, 9", for every two children
- hole punch
- scissors
- colored construction paper
- stapler

Preparation

1. Prepare the plates as follows:
 - A. Cut one half of a plate for each child.
 - B. Make a small slit on each half plate, as shown in Figure A.
 - C. You should have enough plates so that each child has one whole plate and one half plate with a slit.
2. Cut the construction paper into 2" x 4" rectangles. Make one rectangle for each child.
3. Write "Good News" on each rectangle.
4. Cut small shapes out of construction paper to be used for decoration.
5. Make a model of the craft following the instructions.

Instructions

1. Show the children the craft. *This "pouch" says good news. What good news does God want us to share with our friends? (Jesus was born.)*
2. Give the children their plates and have them decorate the backs of them using markers.
3. Make the pouch as follows:
 - A. Help each child staple the front of the half plate to the front of the whole plate, as shown in Figure B. This will create the "pocket" of the pouch.
 - B. Using the hole punch, make two holes on each side of the pocket approximately 1/2" from the plate edges. See Figure C. NOTE: Be careful not to punch a hole in the top half of the whole plate.
 - C. Fold the top half of whole plate down, creating a "flap" over the pocket. See Figure D.
 - D. Cut a tab in the flap that will fit into the slit on the pouch. See Figure E.
4. Have the child glue the construction paper shapes onto the outside of the pouch.
5. Have each child glue the "Good News" paper rectangle onto the front of the pouch.
6. Give each of the children 2 pieces of yarn. Let them thread each piece through the punched holes in the pocket of the pouch. Tie the ends together for them. See Figure F.
7. Tie the pouch around the child's waist.

Conclusion

Give each of the children two invitations to put into their pouches. *Who are you going to give these invitations to? God wants our friends to come to church and hear the good news that Jesus was born.*

Teacher Tips

If your church doesn't have invitations, make some simple invitations for them from construction paper and markers.



Mary Visits Elizabeth

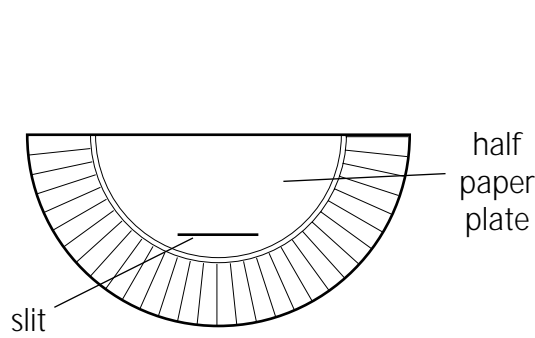

Figure A

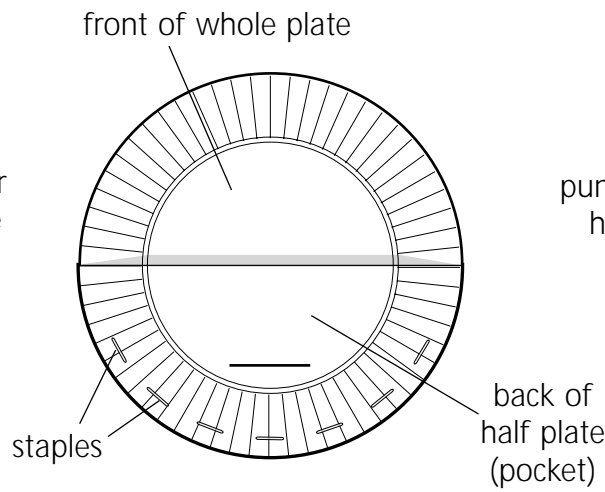

Figure B

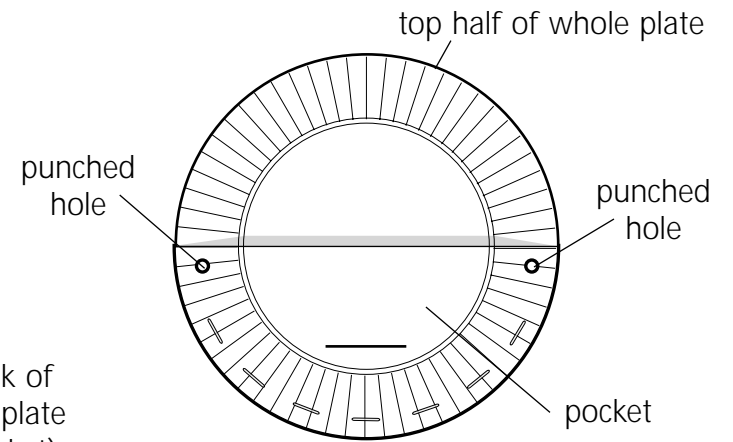

Figure C

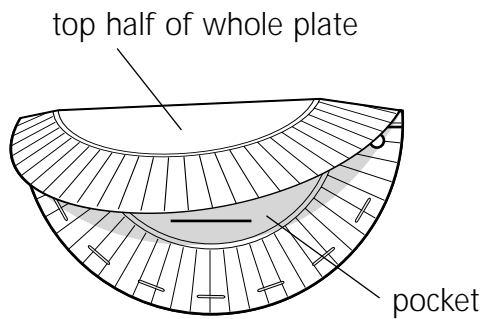

Figure D

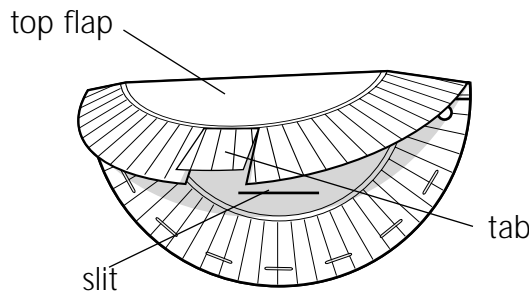

Figure E

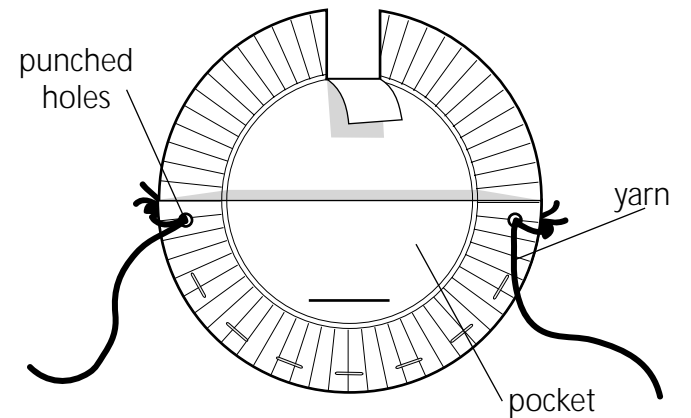

Figure F



Pre class



Mary Visits Elizabeth

Lesson Objectives

- The children will identify Mary and Elizabeth as relatives and good friends who served God.
- The children will each select a person to befriend.
- The children will identify different ways they can share God's "good news."

Lesson Text

Luke 1:39-56

Scripture Memory Verse

"This is my Son, whom I love; with him I am well pleased."
Matthew 3:17

Lesson Plan

Greeting and Registration

Preclass Activity: Friendship Mural

Welcome and Singing

Centers:

Game: Freeze Friends

Craft: Pop-up Puppets

Life Application: Friendship Web

NOTE: Be sure to allow sufficient time for a snack.

Friendship Mural

The children will make a mural of things they like to do with their friends.

Materials

For each child:

- crayons

For the teacher:

- roll of newsprint or poster board
- decorative items such as Easter grass or yarn (optional)
- glue (optional)

Instructions

1. Instruct the children to draw a picture of something they like to do with their friends.
2. Ask each child about what she has drawn. *Tell me about your picture.* Write the child's response underneath her picture. For example, if she says, "I am playing in the park with my friends." Write "playing in the park with my friends."
3. Draw a picture of something YOU like to do with your friends.

Teacher Tips

- The newsprint can be obtained from a local newspaper. They will give you the ends of their rolls.
- The children can use the optional materials to decorate their pictures.





Freeze Friends

The children will act out different things that friends do together.

Materials

For the teacher:

- tape or CD player
- tape or CD of music

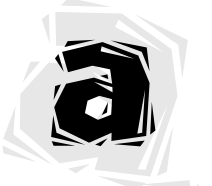

Preparation

Make a list of things that two friends might do together, such as: play ball, eat ice cream, read books, watch movies, paint pictures.



Instructions

1. Separate the children into pairs.
2. Explain the game to the children: *We are going to play a friendship game. I will tell you and your partner to do something that friends do together, like play ball. While I play the music, you pretend that you are playing ball. When the music stops, you stop, freeze, and don't move at all. Then I will give you something else to do and will start the music again.*
3. Practice the game with them to make sure they understand.

Teacher Tips

Tell the children that they are to play the game with "no voice." Tell them that they can't speak at all, or they will not hear when the music stops.

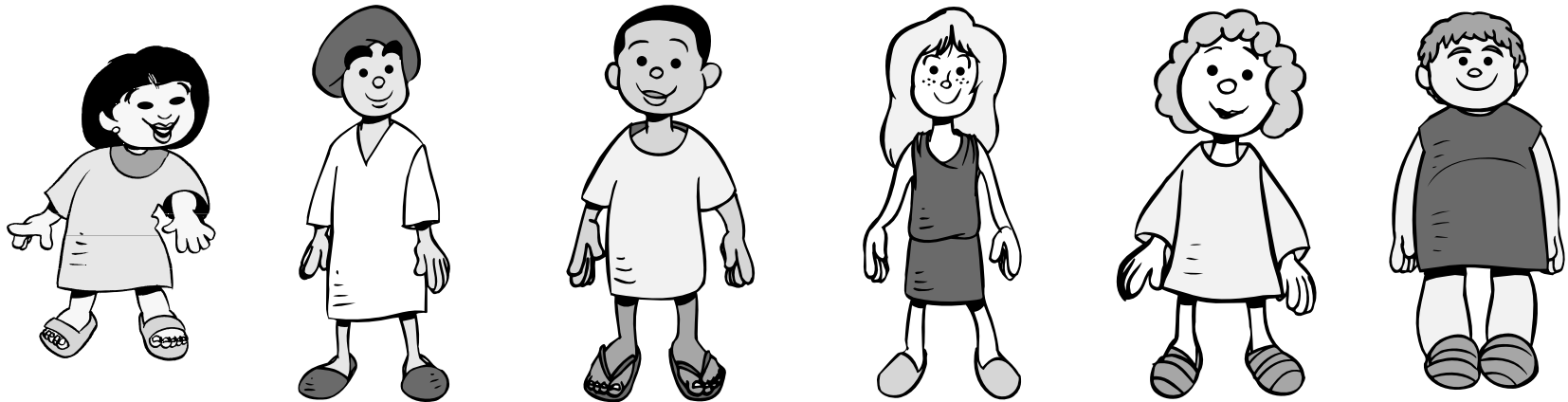

C
R
A
F
T

Pop-up Puppets

The children will make paper bag puppets of Mary and Elizabeth.

Materials

For each child:

- 2 small paper bags
- crayons
- glue stick

For the teacher:

- yarn; gray, brown, black
- fabric scraps
- piece of poster board, 20" x 10"
- marker

Reproducible Pages:

- Page B, 1 copy for the teacher
- Page C, 1 copy for the teacher

Preparation

1. Cut the yarn into 4" pieces to be used for hair.
2. Cut out the puppet clothing stencils from the copy of Reproducible Page B.
3. Trace the stencils onto poster board and then cut them out.
4. For each child, trace and cut out one dress, one shirt and one skirt from the fabric scraps.
5. Make a model of the craft following the instructions.

Instructions

1. Show the children your model and explain to them that they are going to make puppets of Mary and Elizabeth.
2. Give each child two paper bags.
3. Have the children draw faces on each bag.
4. Have the children glue on yarn for hair.
5. Have the children choose and glue the clothes onto their bags to finish the puppets.

Conclusion

As the children are finishing their puppets, review what they know about Mary and Elizabeth. Ask them questions and remind them that Mary and Elizabeth were good friends. Explain to them that they served God together.

Teacher Tip

Have the children use the puppets to act out the different things that Mary and Elizabeth did together.

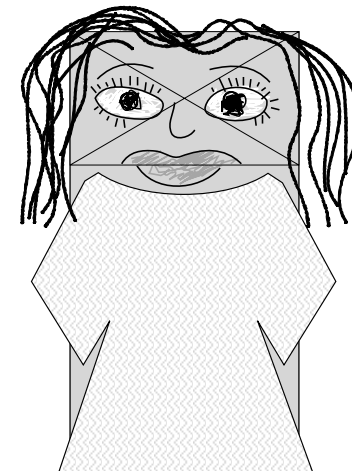

supplement

CRAFT

Mary Visits Elizabeth

Jesus
Lesson 2

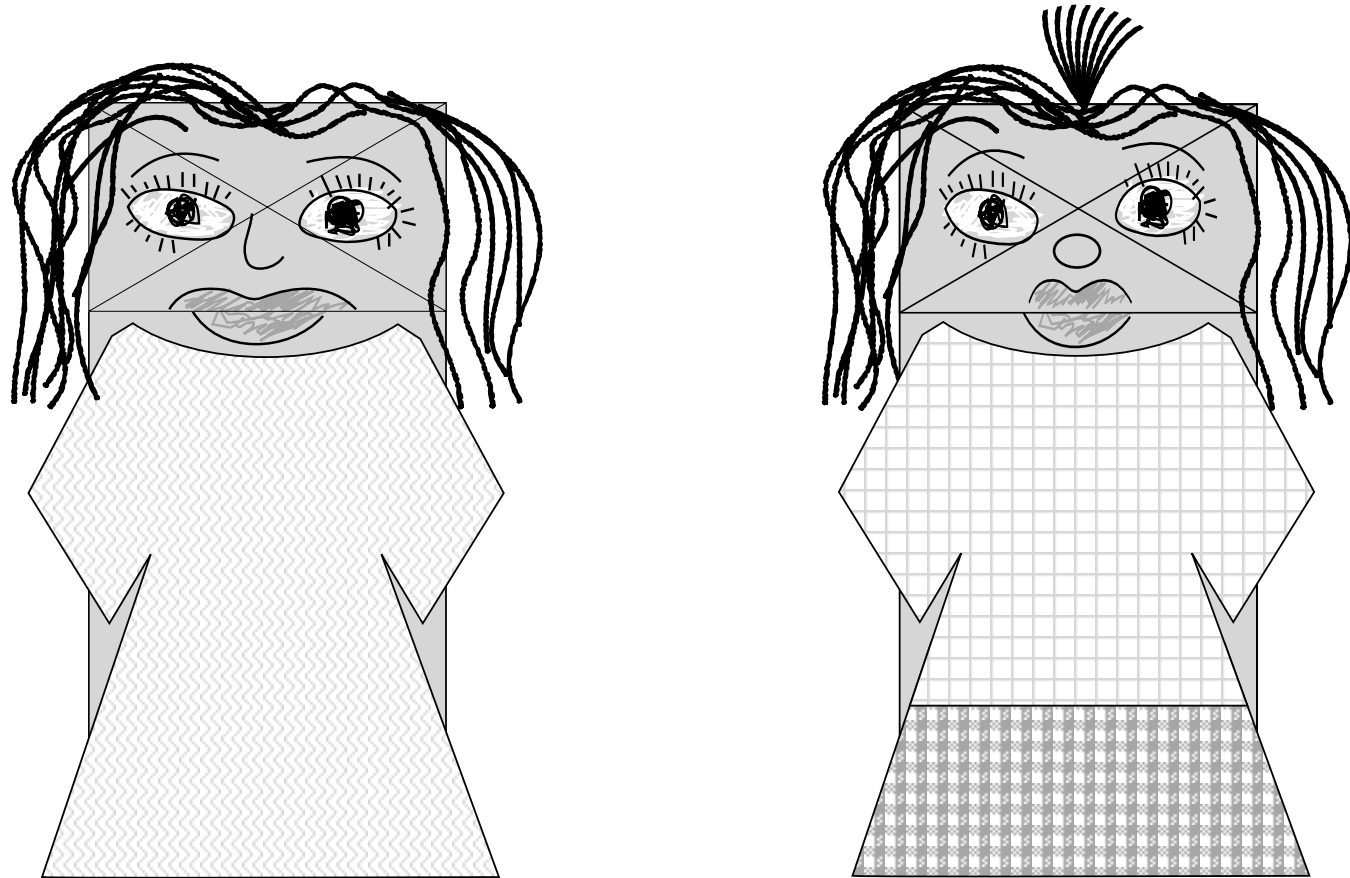

Finished Craft



Mary Visits Elizabeth

Friendship Web

The children will help construct a Word Web about friendship.

Scripture Memory Verse

"This is my Son, whom I love; with him I am well pleased."

Matthew 3:17

Materials

For the teacher:

- magazines
- 1 piece of poster board or a large white piece of paper
- 3" x 5" cards or pieces of paper
- scissors

Preparation

Cut out pictures from the magazines that illustrate things that friends do together.

Instructions

Ask the children what they talked about in the Preclass Activity. *That's right. You talked about friends.*

Write the word "friend" in the middle of the poster board. *We are going to make a Word Web. In the middle of the web, I wrote the word, friend.*

Here are pictures of friends doing different things together. Hold up one of the pictures, for example, a picture of people playing ball. What are these friends doing in this picture? That's right, they're playing ball. Write the words "play ball" on the poster board, tape the picture above the words, and draw a line from the picture to the word, friend. See Figure A.

Continue in this manner with each of the pictures that you cut out of the magazines. Ask the children: *Are there other things that you like to do with your friends?* As the children answer, write words for their ideas on the poster board and draw lines from their words to the word, friend. You may also choose to draw pictures of their ideas.

After you have used all of the pictures and collected enough ideas, continue a discussion with the children about where we can find our friends, asking them questions, such as:

- Should we be friends with people we meet at school?
- Should we be friendly when we meet new people with our mom?
- Can we make new friends at the park or the library?

Scripture Memory Activity

Ask the children: *Who remembers the memory scripture?* Choose a child to whisper the scripture in your ear. If correct, have them encourage their friends to remember by giving them hints.

Hints should be short and easy, such as the first few words of the scripture.

Conclusion

Let's thank God for giving us friends. Choose a child to pray and thank God for our friends.

Jesus taught us how to be friends. He talked with his friends about God. Who do you want to tell about God this week? Have each child name a friend they will tell about God this week. Write the name of each child's friend on a 3" x 5" card and give it to them to take home. This card will help to remind you to talk to your friend about God.

Teacher Tips

On the back of the poster board create another word web with the word "friend" asking the children: Who are our friends?



Mary Visits Elizabeth



play ball

Friend

Read-Aloud Bible

Page

A

Mary's Visit—Luke 1:39-56

It all happened a very long time ago, but I remember how happy I was when God told me I was going to be the mother of Jesus. I just had to take a trip to see Elizabeth, my relative and friend, and tell her my exciting news! Elizabeth was also going to have a baby. We were both going to have babies! Her baby was going to be called John. John would become Jesus' relative and friend.

I could hardly wait to see Elizabeth. As I walked into her house, she was very happy to see me! She said that when she heard my voice, her baby jumped inside her! (Luke 1:42-45).

There was so much to talk about, and so much to do to get ready for our babies, that I stayed at Elizabeth's house until it was time for her baby to be born. I enjoyed being able to help Elizabeth with her work. I was so glad I could help my friend.

We had to carry water from the well every day. We cleaned the house, washed the clothes and cooked the meals. We also prayed together every day and worshipped God. Many times we visited with Elizabeth's neighbors, talking with them about our happy news and about God.

We loved our long visit together. We loved being friends.

Supplement/Craft
1 copy for the teacher

Discipleship

Page

B

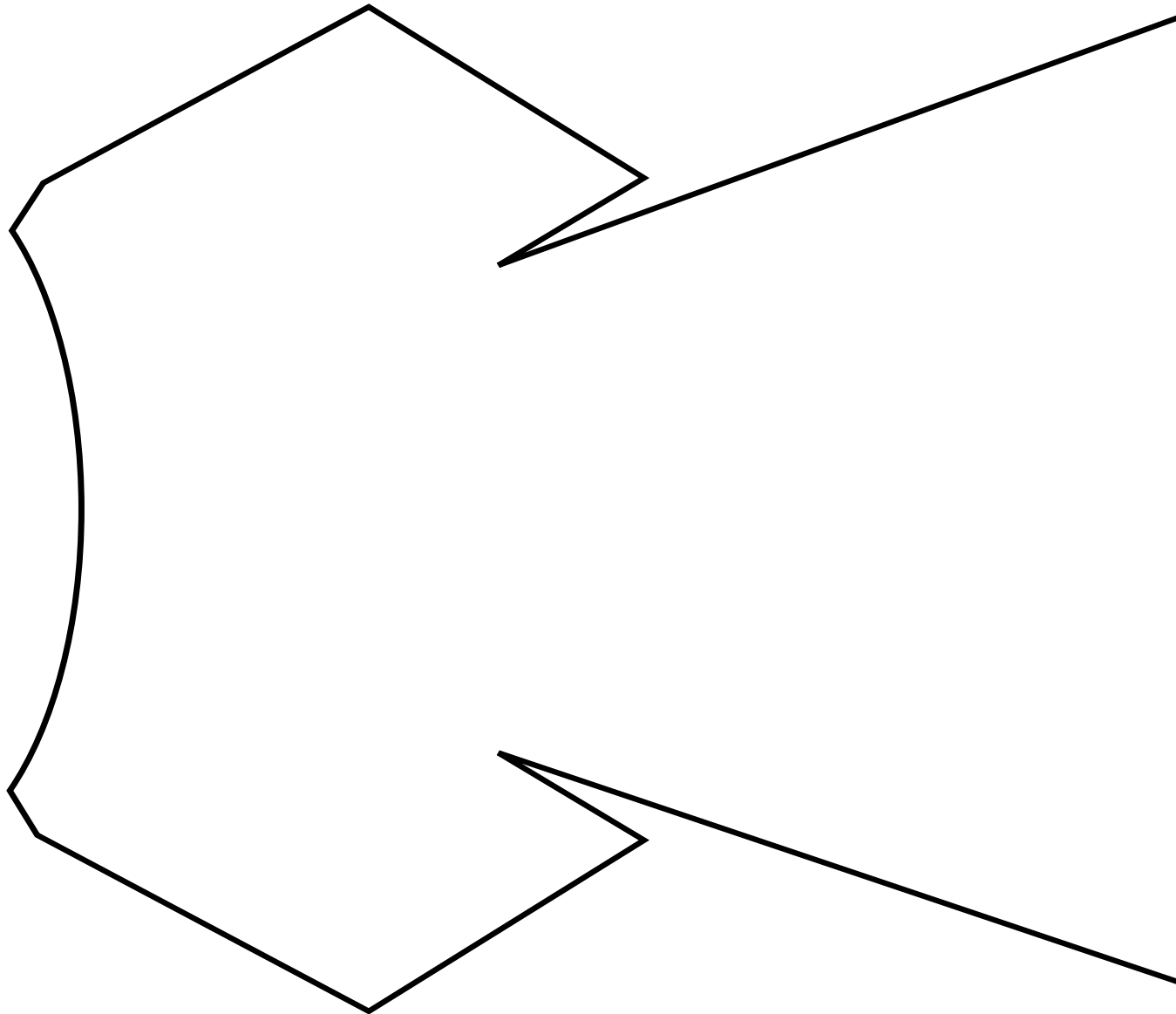

puppet clothing stencil



4 and 5 Year Olds

Supplement/Craft
1 copy for the teacher

Jesus
Lesson 2

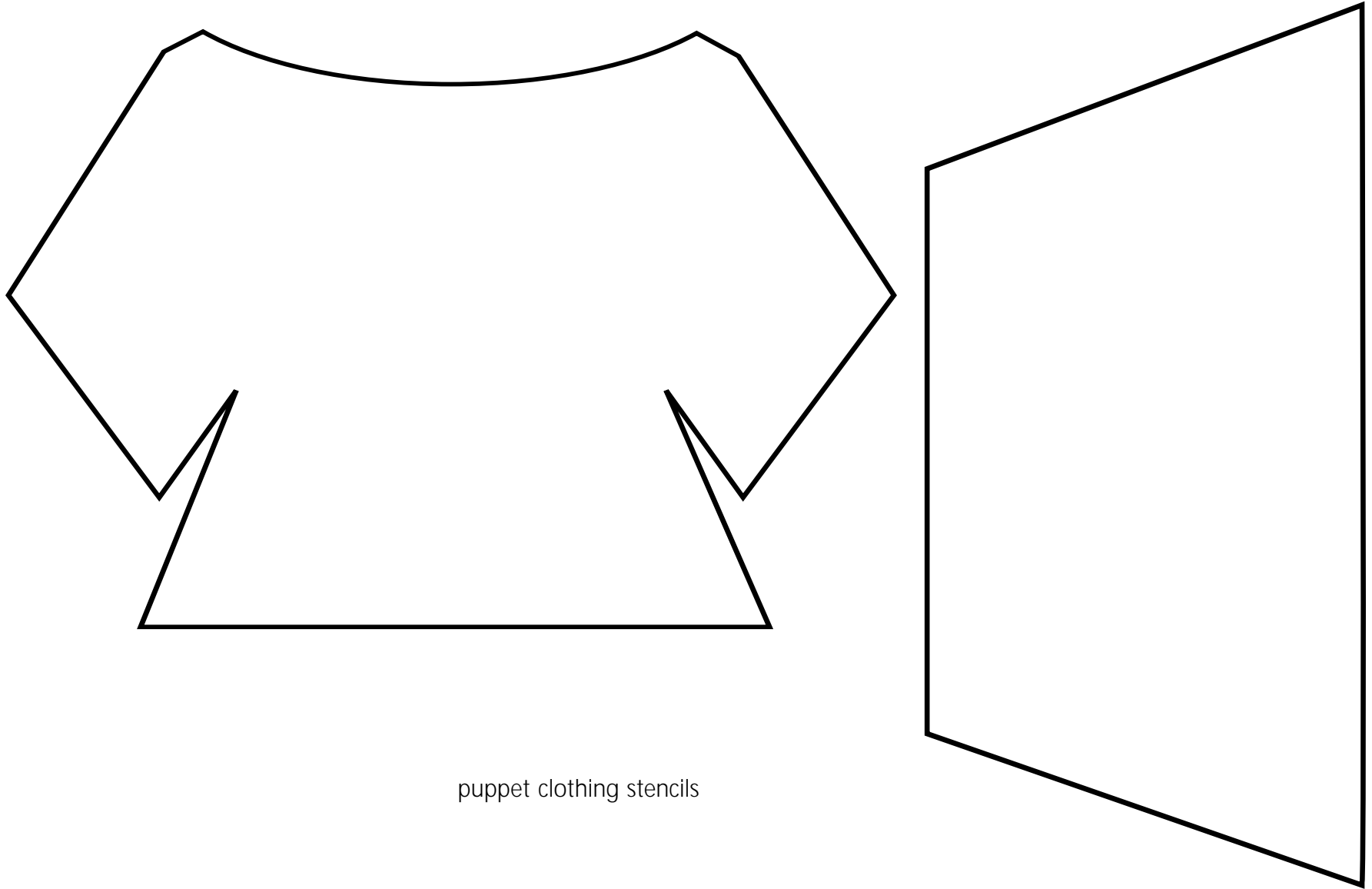

puppet clothing stencils